

ML200 MASTER 200



ADD F1-5, Block 3, No.95, Guangzhu Rd, Lanhe Town, Nansha District, Guangzhou 511480

Tel. +86 20 8499 2310/2320/2330

Fax +86 20 8499 2360

E-mail info@color-imagination.com

Website www.color-imagination.com

**Follow
us on**



www.facebook.com/color.imagination.1



www.youtube.com/user/colorimaginationj



https://twitter.com/Color_lighting

CE   IP20 t_a40°C t_c100°C

User Manual

KEEP THIS MANUAL FOR FUTURE NEEDS

1 SAFETY INSTRUCTIONS



CAUTION

Be careful with your operations. With a dangerous voltage you can suffer a dangerous electric shock when touching wires!

This device has left the factory in perfect condition. In order to maintain this condition and to ensure a safe operation, it is absolutely necessary for the user to follow the safety instructions and warning notes written in this user manual.



IMPORTANT

Damages caused by the disregard of this user manual are not subject to warranty. The dealer will not accept liability for any resulting defects or problems.

If the device has been exposed to temperature changes due to environmental changes, do not switch it on immediately. The arising condensation could damage the device. Leave the device switched off until it has reached room temperature.

This device falls under protection-class I. Therefore it is essential that the device be earthed.

The electric connection must carry out by qualified person.

The device shall only be used with rated voltage and frequency.

Make sure that the available voltage is not higher than stated at the end of this manual.

Make sure the power cord is never crimped or damaged by sharp edges. If this would be the case, replacement of the cable must be done by an authorized dealer.

Always disconnect from the mains, when the device is not in use or before cleaning it. Only handle the power cord by the plug. Never pull out the plug by tugging the power cord.

During initial start-up some smoke or smell may arise. This is a normal process and does not necessarily mean that the device is defective, it should decrease gradually.

Please don't project the beam onto combustible substances.

Fixtures cannot be installed on combustible substances, keep more than 50cm distance with wall for smooth air flow, so there should be no shelter for fans and ventilation for heat radiation.

If the external flexible cable or cord of this luminaire is damaged, it shall be exclusively replaced by the manufacturer or his service agent or a similar qualified person in order to avoid a hazard.

8 MAINTENANCE AND CLEANING

The following points have to be considered during the inspection:

- 1) All screws for installing the devices or parts of the device have to be tightly connected and must not be corroded.
- 2) There must not be any deformations on the housing, color lenses, fixations and installation spots (ceiling, suspension, trussing).
- 3) Mechanically moved parts must not show any traces of wearing and must not rotate with unbalances.
- 4) The electric power supply cables must not show any damage, material fatigue or sediments.

Further instructions depending on the installation spot and usage have to be adhered to by a skilled installer and any safety problems have to be removed.



CAUTION

Disconnect from mains before starting maintenance operation.



In order to make the lights in good condition and extend the life time, we suggest a regular cleaning to the lights.

- 1) Clean the inside and outside lens each week to avoid the weakness of the lights due to accumulation of dust.
- 2) Clean the fan each week.
- 3) A detailed electric check by approved electrical engineer each three months, make sure that the circuit contacts are in good condition, prevent the poor contact of circuit from overheating.

We recommend a frequent cleaning of the device. Please use a moist, lint-free cloth. Never use alcohol or solvents.

There are no serviceable parts inside the device. Please refer to the instructions under "Installation instructions".

Should you need any spare parts, please order genuine parts from your local dealer.

2 UNPACKING

1.8° Angle, Ø160mm Front Lens, Front Neon Ring, 2 Prism Wheels, Continuous PAN/TILT

The MASTER 200 is an ultra compact and light weight stylish LED moving head beam light with an OSRAM 8500K 200W LED module, integrated with a set of unique high resolution optical system (160cm front lens).

The fixture features 1.8° beam angle which helps to provide ultra long throw solid beam effect. The front ring strip light delivers a magic lighting effect created by 30*0.2W 3-IN-1 SMD RGB LEDs. The MASTER 200 is designed with a range of effects: 13 static gobos, 13 dichroic colors, 6-Color Wheel, 2 prism wheels, frost, focus, etc. It provides 360° continuous fast and smooth PAN/TILT movement with variable speed which delivers even more vivid visual effect to the show. The fixture supports DMX, RDM (Remote Device Management).

The fixture's exterior housing is beautifully balanced basing on a modern design philosophy with supremely harmonious interior structure for remarkable control. The sculpted body of the MASTER 200 achieves more than just a striking look. The 2*1/4 turn fastening omega clamps, available for vertical and horizontal plug-in, make installations fast and easy.

It's fast and quiet operation LED moving head beam. It's a perfect option for indoor application like large scale live concerts, TV productions, road shows, conference halls, clubs, etc.

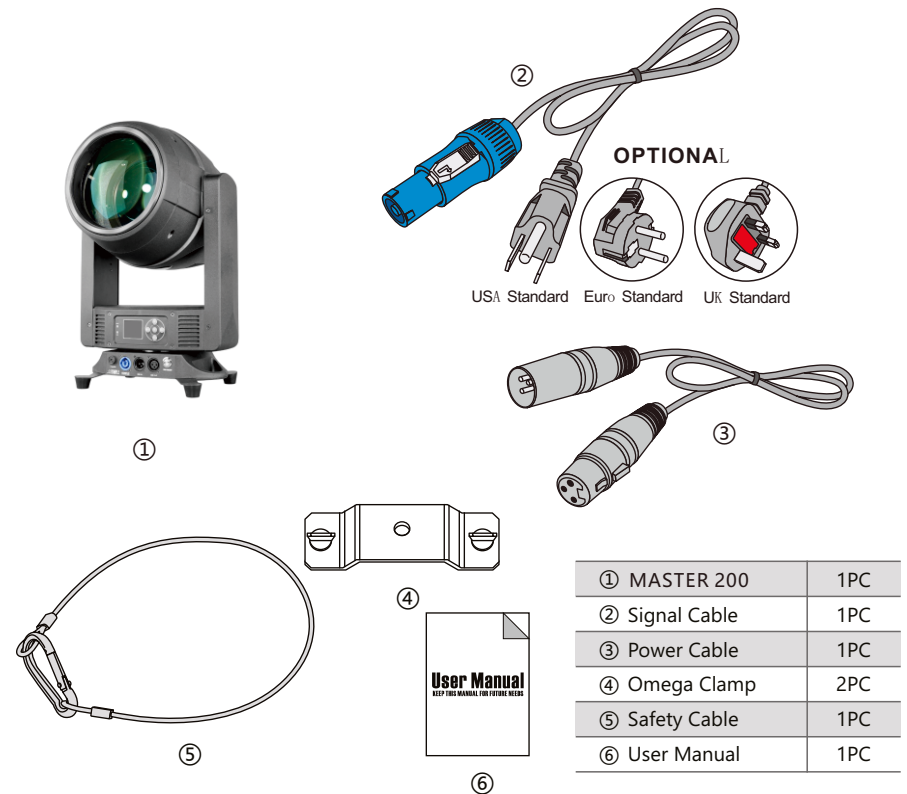

3 FEATURES & SPECIFICATIONS

1*OSRAM 200W LED module

30*0.2W 3-IN-1 RGB LEDs

Color Temperature: 8500K

CRI: ≥70

A set of high resolution and precise optics

Ø160mm Front lens

1.8°Beam angle

Smooth and precise linear focus

PAN: 2 modes

1. 360°Continuous movement

2. 540°(8/16 bit)

TILT: 2 modes

1. 360°Continuous movement

2. 270°(8/16 bit)

Fast, quiet, smooth and precise 2-Phase motors

Smooth, fast and precise resolution for PAN/TILT movement with low noise operation

Scan position memory, auto reposition after unexpected movement

PAN/TILT reversible

1 Color wheel with 13 dichroic colors plus open

Variable direction rainbow effect with speed adjustable

6-Color wheel with variable direction and speed control

1- ring strip effect with different built-in macro effects (variable speed control)

1 Static gobo wheel with 13 gobos plus open

2 Prism wheel design

Prism 1: 3 different prisms, 5-Facet linear prism/8-Facet circular prism/4+8+16-facet circular

prism with variable speed and direction

Prism 2: 3 different prisms, 6-Facet linear prism/16-facet circular prism/8+16-facet circular

prism with variable speed and direction

Prism indexing

Prism overlay (prism morphing)

0-25Hz shutter/strobe effect with variable speed

Preset variable/random strobe and dimming pulse effect

Even and soft coverage

0-100% Smooth linear dimming

21 DMX channels USITT DMX-512

DMX512, master-slave, or auto operation

DMX recorder and edit function integrated

RDM available (Remote Device Management)

Art-NET (Optional)

Wireless receiver system built-in (Optional)

Shielded input signal protection for stable signal without interference

RJ45 etherCON IN/OUT (Optional with Art-Net)

3-Pin and 5-pin XLR DMX connectors IN/OUT

Electronic supply with active PFC

AC100-240V 50/60Hz

PowerCON IN/ OUT with fuse

290W Power consumption

-25°C to 45°C ambient temperature

IP20 protection rating

		216-220	Dither pattern 6 from slow to fast
		221-225	Dither pattern 7 from slow to fast
		226-230	Dither pattern 8 from slow to fast
		231-235	Jitter pattern 9 from slow to fast
		236-240	The slow to fast dither pattern 10
		241-245	Dither pattern 11 from slow to fast
		246-250	The slow to fast dither pattern 12
		251-255	Dither pattern 13 from slow to fast
[CH13]	Prism 1	0-63	without
		64-127	Insert prism 1
		128-191	Insert prism 1
		192-255	Insert prism 1
[CH14]	Prism rotation	0-127	0-360 degrees
		128-190	From fast to slow forward flow
		191-192	stop
		193-255	Reverse flow from slow to fast
[CH15]	Prism 2	0-63	without
		64-127	Insert prism 2
		128-191	Insert prism 2
		192-255	Insert prism 2
[CH16]	Prism 2 rotates	0-127	0-360 degrees
		128-190	Reverse flow from fast to slow
		191-192	stop
		193-255	From slow to fast forward flow
[CH17]	Colorful mirror	0-127	without
		128-255	various colours
[CH18]	focus	0-255	From far to near
[CH19]	Reset/Function	0-209	No function
		210-215	Reset XY motor after 3 seconds.
		216-219	No function
		220-235	Reset the effect motor after 3 seconds.
		236-239	No function
		240-255	Reset the whole lamp after 3 seconds.
[CH20]	effect	0-255	
[CH21]	Effect speed	0-255	

		55-59	Color 5+ color 6
		60-64	Color 6
		65-69	Color 6+ color 7
		70-74	Color 7
		75-79	Color 7+ color 8
		80-84	Color 8
		85-89	Color 8+ color 9
		90-94	Color 9
		95-99	Color 9+ color 10
		100-104	Color 10
		105-109	Color 10+ color 11
		110-114	Color 11
		115-119	Color 11+ color 12
		120-124	Color 12
		125-129	Color 12+ color 13
		130-134	Color 13
		135-139	Color 13+ color 14
		140-200	From fast to slow forward flow
		201-255	Reverse flow from slow to fast
[CH12]	Chart plate	0-4	white light
		5-9	Pattern 1
		10-14	Pattern 2
		15-19	Pattern 3
		20-24	Pattern 4
		25-29	Pattern 5
		30-34	Pattern 6
		35-39	Pattern 7
		40-44	Pattern 8
		45-49	Pattern 9
		50-54	Pattern 10
		55-59	Pattern 11
		60-64	Pattern 12
		65-69	Pattern 13
		70-129	Reverse flow from fast to slow
		130-134	white light
		135-190	From slow to fast forward flow
		191-195	Dither pattern 1 from slow to fast
		196-200	Dither pattern 2 from slow to fast
		201-205	Dither pattern 3 from slow to fast
206-210	Dither pattern 4 from slow to fast		
211-215	Dither pattern 5 from slow to fast		

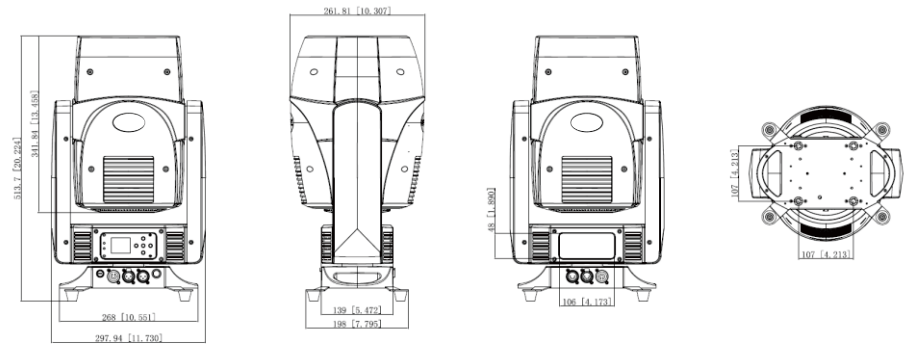

4 PHOTOMETRIC DATA

Photometric Beam Angle Data 1.8° Beam Angle $LUX \times 0.0929 = FC$

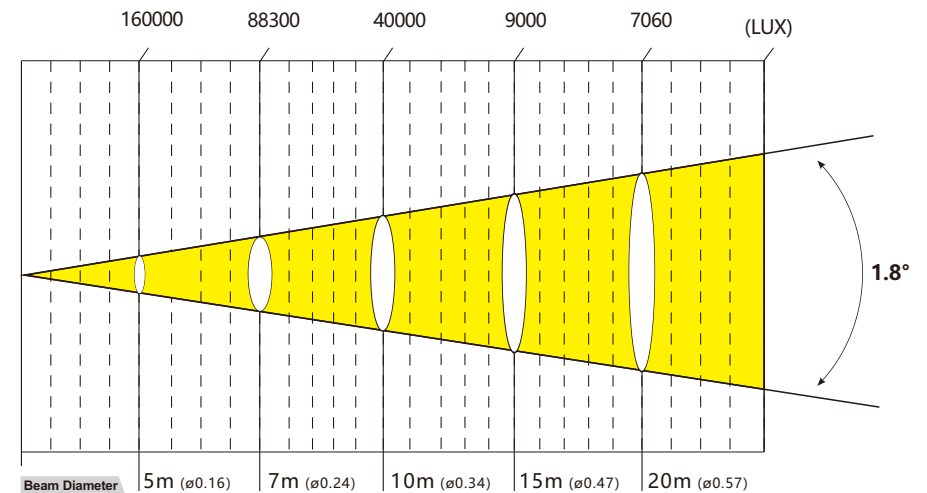

5 DMX-512 CONTROL CONNECTIONS

Connect the provided XLR cable to the female 3-pin XLR output of your controller and the other side to the male 3-pin XLR input of the architectural. You can chain multiple

Architectural together through serial linking. The cable needed should be two core, screened cable with XLR input and output connectors. Please refer to the diagram below.

DMX-512 connection with DMX terminator.

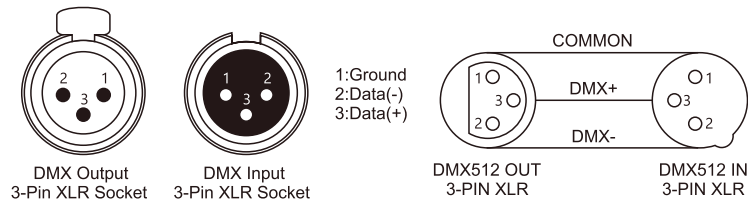

For installations where the DMX cable has to run a long distance or is in an electrically noisy environment, such as in a discotheque, it is recommended to use a DMX terminator. This helps in preventing corruption of the digital control signal by electrical noise. The DMX terminator is simply an XLR plug with a 120 Ω resistor connected between pins 2 and 3, which is then plugged into the output XLR socket of the last fixture in the chain. Please see illustrations below.

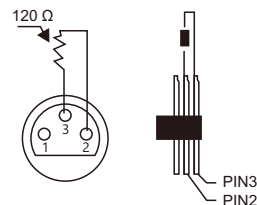

7 DMX CHANNELS

Channel 1	name	numerical value	describe
[CH1]	X- rotation	0-255	
		0-127	without
		128-191	From fast to slow forward flow
		192-255	Reverse flow from slow to fast
[CH2]	Y- rotation	0-255	
		0-127	without
		128-191	From fast to slow forward flow
		192-255	Reverse flow from slow to fast
[CH3]	X axis	0-255	0-540 degrees
[CH4]	Y axis	0-255	0-270 degrees
[CH5]	X-axis fine tuning	0-255	0-2 degrees
[CH6]	Y axis fine tuning	0-255	0-1 degree
[CH7]	XY speed	0-255	From fast to slow
[CH8]	atomize	0-127	without
		128-255	atomize
[CH9]	stroboscopic	0-3	Guan guang
		4-127	From slow to fast pulse stroboscopic
		128-191	Gradual frequency conversion flash from slow to fast
		192-251	Random strobe from slow to fast
		252-255	switch
[CH10]	aiming	0-255	0-100% dimming
[CH11]	colour disc	0-4	white light
		5-9	White light+color 1
		10-14	Color 1
		15-19	Color 1+ Color 2
		20-24	Color 2
		25-29	Color 2+ color 3
		30-34	Color 3
		35-39	Color 3+ color 4
		40-44	Color 4
		45-49	Color 4+ color 5
		50-54	Color 5

		RDM.
	model	The model of lamps and lanterns is the same as the model information of RDM.
	display panel	Firmware version and serial number of display board
	Main board 1	Firmware version and serial number of motherboard 1
Light source time	Record the total cumulative time of turning on the light source, in minutes, which is cleared manually by the user as a time reference for regular maintenance of the light source.	
Lamp time	Record the total cumulative time for turning on lamps and lanterns, in minutes, which cannot be cleared.	

6 MENU OPERATIONS

operational mode

DMX mode	Console mode, receiving DMX signal, RDM signal.	
Self-propelled mode	Lamps run automatically according to the built-in program.	
Voice control mode	When the lamp detects a strong sound, the lamp automatically runs a scene according to the built-in program, otherwise the last scene is kept.	
Scene mode 01	Run in the set scene mode, and support custom editing of up to 10 scenes.	
	1~10	Output the specified scene.
	automatic	Automatically output scenes in the sequence of set scene time (non-0), and automatically skip and ignore scenes with time of 0.
Master-slave selection	Non-DMX mode takes effect, and the data output mode is selected. The lamps automatically detect the DMX state and automatically switch the output to prevent data conflict.	
	host machine	Lamps and lanterns according to the built-in operation, if DMX no signal, output data (synchronization), otherwise don't output data.
	From the machine	Lamps and lanterns according to the built-in operation, no output data (not synchronized with other lamps and lanterns).
	automatic	If there is no signal from DMX, the lamps will run according to the built-in operation; otherwise, the lamps will work according to the DMX signal.
Light bulb switch	The confirmation dialog box pops up (bulb light source), select "SURE" to confirm the current operation, turn on or off the bulb, and the switching time interval is limited to 30 seconds.	
	close	The current bulb output has been turned off.
	open	The current light output is already on.

display setting

language	Set the displayed language.	
	English	English display
	Chinese	Chinese display
screen saver	Set the display content or mode of the screen after no operation for 30 seconds.	
	close	Keep the last operation page and highlight the screen.
	Mode 1	Screen extinction
	Mode 2	Black screen, showing the address code of the current lamp in the lower left corner.
Mode 3	Display trademark information, address code and operation mode.	
Screen rotation	Set the display direction of the screen.	
	close	Non-inverted display
	open	Inverted display
	automatic	Automatically detect the hanging direction of lamps, and automatically switch the display direction.

DMX indication	Set the indication mode of DMX signal indicator.	
	Mode 1	Lights when there is a signal, and goes out when there is no signal.
	Mode 2	When there is a signal, it goes out, and when there is no signal, it lights up.
	Mode 3	Flashes when there is a signal and goes out when there is no signal.
Signal indicating brightness	Set the brightness of the signal indicator.	
	1~10	10 grades
Screen backlight	Set the brightness of the screen backlight after 10 seconds of no operation, and it will be fully lit when it is operated.	
	1~10	10 grades
Touch screen switch	Choose whether to disable the touch screen. When the touch screen is accidentally damaged, you can disable the touch function and use the auxiliary input to set the lamps.	
Touch correction	When the screen touch is not accurate, you can enter the correction page correction screen.	

Scene mode

Scene selection	Select the scene to be operated at present.	
	1~10	10 scene settings
Scene time	Set the retention time of the current scene in automatic mode, with the unit of 0.1 second.	
	0	The current scene does not participate in automatic scene output.
	1-255	0.1 seconds to 25.5 seconds
1. X axis	0-255	Set the data of each channel, and the display content and sequence correspond to the channel table of lamps one by one.
.....	0-255	
.....	0-255	
Function	0-255	

Advanced settings

X-axis inversion	Set the x-axis rotation direction.	
	close	Not reversed
	open	opposite direction
Y-axis inversion	Set the y-axis rotation direction.	
	close	Not reversed
	open	opposite direction
Optical coupler correction	Set whether lamps detect XY out-of-step and correct it.	
	close	Do not correct the position after out of step.
	open	Automatic position correction after out-of-step
X axis offset	Set the position of the zero point of the lamp X axis.	
	4-150	
Y axis offset	Set the position of Y-axis zero point of lamps and lanterns.	
	4-48	
Data retention	Set the output state of lamps and lanterns without DMX signal.	
	close	There is no signal, so the motor and light source return to the position and state when the reset is completed.
	open	No signal, keep the last frame of DMX data output.

Light-on mode	Set the way to turn on the light bulb for the first time after it is powered on.	
	Power-on bubble	Turn on the light bulb first, and reset the lamp after 30 seconds.
	Bubble opening after reset	Reset the lamp after 3 seconds of power-on, and turn on the bulb after the reset is completed.
	Manual foaming	After the reset is completed, manually turn on the light bulb through the menu or console.
Factory settings	The confirmation box pops up, and after selecting "SURE", the parameters of lamps and lanterns will return to the factory settings.	

status messages

Motor information	Displays the information status of all motors and signals in the lamp.	
	Hall	If it is not displayed, it means that the motor has no Hall correction, 0 means that the motor leaves the correction position point, and 1 means that the motor is at the correction position point.
	condition	Displays the motor reset completion status.
	X axis	Display the real-time position value of X-axis optocoupler feedback.
	Y axis	Display the real-time position value of Y-axis optocoupler feedback.
	Optocoupler	Displays the level status of two signals of X-axis and Y-axis optocoupler, binary.
Fault/status record	Display the latest 8 fault records of lamps when they are reset and running.	
	Fault data	Total number of faults detected after power-on.
	12: :03	Power-on time when the fault occurs, in minutes.
	Hall fault	When the corresponding motor is reset, the motor does not detect an effective Hall signal.
	Hall short circuit	When the motor is reset, the Hall signal of the motor is always valid.
	Optocoupler	No effective optocoupler signal was detected when the corresponding motor was reset.
	be out of step	The corresponding motor is out of step during operation.
	Hit the rod	When the corresponding motor is reset, it hits the positioning rod.
	Bulb failure	Accidental bubble extinction of light bulb
	Sensor failure	The temperature sensor signal is abnormal,
	Fan failure	The main fan is not working properly.
Lamp state	Displays the key status data of the current lamps for reference.	
	communication	0~100%, communication quality of internal data link of lamps and lanterns.
	miscount	Total number of error frames detected after power-on, cumulative
	Light source temperature	Displays the temperature of the current light source, and "-" indicates no detection.
	Display panel temperature	Displays the temperature of the current display panel or the ambient temperature nearby.
	Sensor temperature	1 Displays the current motherboard temperature or the ambient temperature of the motherboard installation location.
Version information	Display the information and version of current lamps, which is an important reference for after-sales maintenance.	
	equipment	The name of the lamp is the same as the equipment information of